

Q RANGE



BRITAIN'S LEADING
TRAILER MANUFACTURER

In Safe Hands

SPECIALISTS IN TRAILER DESIGN & ENGINEERING

For over 60 years, people have put their trust in our trailers, just ask an owner – they are not difficult to find. As specialists in trailer design and engineering, we have continued to set the standard both in the UK and throughout much of Europe.

We are an independent company with one focus: to build the best products on the market. More than 30,000 people choose our trailers each year – but we are not standing still. Our dedicated investment in new technologies and materials ensures that our products continue to exceed the expectations of our customers. We know that quality, strength, value and ease of maintenance are of vital importance to you. That is why we have made them the driving force behind everything we do.



Q7b Road with roof and rack, hinged mesh sides, lightguards and propstands

The new Q Range from Ifor Williams Trailers

The Q Range are engineered for professional use and are built to last. They come in rugged sizes from 1.5m x 1m (5' x 3' – Q5) to 2.5m x 1.45m (8' x 4'9" – Q8).

There are many small lightweight trailers on the market today but very few can boast the leaf spring suspension and therefore the durability provided by this trailer range. The multipurpose range can be towed behind ATV's or cars (dependent on model chosen*).

Versatility

With its high sides and range of accessories the Q range is an exceptionally versatile trailer. While the Q trailer is ideal for many farming applications, it is also ideal for other industries such as building, landscaping and forestry.

Why choose a Q Trailer?

The essential difference between the Q range and the similarly sized IWT P*e range of unbraked trailers are:

- Higher sides
- Leaf spring suspension
- A covered floor as standard
- Braked options
- Hot dipped, welded galvanised
- Innovative roof and rack option
- Metal mudguards

There are many other makes of 'farmers' trailers on the market. The combination of leaf spring suspension, durable build, innovative accessories and smart finish help distinguish the Q trailer range from competitors.

*Please check towing vehicle manufacturer's handbook for maximum unbraked towing limit.



Q5e Road with hinged mesh sides



Q5e off-road with internal partition. The partition can be located in multiple positions allowing flexibility around the farm.



Leaf spring suspension





Q5e road with hinged mesh sides

Q5e Off-Road/Road

Q5 is a compact and robust trailer which comes in two variants: off-road only versions and a dual version suitable for both road and off-road. The trailer is available with either mesh or solid hinged sides as well as stock ramp and propstands.

The off-road trailer comes without lights or mudguards—meaning it is specifically for off-road use and makes the trailer less expensive and lighter than its road alternative.

The Q5 has a bed size of 1.5m x 1m (5' x 3'3") and is available in either 750kg or 350kg gross weight. (See specifications on page 11). There are two options for tyres on the off-road Q5e trailer – either the flotation tyres (20.5 x 8-10) or the knobbly tyres (22 x 11-8). The latter have a very deep tread depth which helps the trailer stay on track behind the towing vehicle in muddy conditions or hilly terrain.

A 360 degree swivel hitch is available for both Q5 off-road trailers.

Tyre Options

Knobbly tyres vs Flotation tyres

- The knobbly option has a greater tread depth but a lighter maximum GVW.
- The knobbly tyre is best for use in muddy conditions and hilly terrain.
- The knobbly option is not road legal – purely for off-road use.
- Flotation tyres offer a load spreading profile suitable for soft ground are road legal and have a higher maximum GVW.



Q5 Q5e off-road and road versions showing different ramp, hinged sides and internal partition options





Q6 Q6e off-road with internal partition and hinged solid sides



Q6 Q6e off road with flotation tyres showing different ramp, hinged sides and internal partition options



Q6 & 7 Off-Road

The Q6 and Q7 have a bed width of 1.22m (4') and bed lengths of 1.95m (6'4") and 2.19m (7'2"), with 750kg GVW. This means they are solely for off-road use and come with a range of additional accessories and options.

The floor is durable pressure treated timber planking covered with aluminium treadplate and both trailers come with formed side panels for extra strength and are hot dip galvanised for the renowned Ifor Williams durability. They have a gross maximum weight of 750kg and feature the exclusive Ifor Williams beam axle and leaf spring suspension system which has been developed and refined for a safe and stable ride. This gives superior durability and reliability over the normal rubber torsion suspension systems found on similar trailers of this size.

Both the Q6 and Q7 have the options of either hinged mesh sides or hinged solid sides as well as a roof and rack, stock ramp with stock door or simply a ramp. The roof and rack* is ideal for carrying feed or fencing posts when animals or other items are inside. A cross division option is also available which has an integrated door for internal access.

*The roof and rack has a maximum recommended weight of 50kg and uses two fasteners which are easily removed.



Q7

Q7b road with roof and rack and hinged solid sides



Q7

Q7b/e road showing a variety of options



Q6, 7 & 8 Road

The Q6 and Q7 have a bed width of 1.22m (4') and bed lengths of 1.95m (6'4") and 2.19m (7'2"). The Q8 has a bed width of 1.45m (4'10") and a bed length of 2.51m (8'). All braked versions have a GVW of 1000kg whilst the unbraked trailers have a GVW of 750kg.

These trailers have the durable pressure treated timber, renowned Ifor Williams leaf spring suspension and one piece treadplate floor as well as hot dip galvanised finish. All this ensures the trailer's hardness and reliability for the many tasks it will be used for over the many years it will be in service.

The roof and rack option is helpful for keeping contents dry as well as being able to carry fencing posts or a whole range of other materials*. The numerous tie-down points on the roof and rack allow any load to be secured at any point along.

The majority of quad bikes will fit inside the Q7 with some makes of golf buggies fitting in the Q8.

* The roof and rack has a maximum recommended weight of 50kg and uses two fasteners which are easily removed.



Q7e road with roof and rack, hinged mesh sides, stock ramp door, internal partition and propstands

Dimensions

Dimensions in Metres	Unbraked/Braked	Maximum Gross Weight	A	W	L	D	E	F
Q5e Off-Road	Unbraked	350kg@40kph	0.32	1.02	1.51	1.52	2.6	1.27
Q5e Off-Road	Unbraked	750kg	0.32	1.02	1.51	1.52	2.6	1.27
Q6e Off-Road	Unbraked	750kg	0.38	1.22	1.95	1.71	3.02	1.28
Q7e Off-Road	Unbraked	750kg	0.38	1.22	2.19	1.71	3.27	1.28
Q5e Road	Unbraked	750kg	0.32	1.02	1.51	1.52	2.6	1.27
Q6e Road	Unbraked	750kg	0.38	1.22	1.95	1.71	3.02	1.28
Q7e Road	Unbraked	750kg	0.38	1.22	2.19	1.71	3.27	1.28
Q6b Road	Braked	1000kg	0.38	1.22	1.95	1.71	3.02	1.28
Q7b Road	Braked	1000kg	0.38	1.22	2.19	1.71	3.27	1.28
Q8b Road	Braked	1000kg	0.36	1.45	2.51	1.95	3.62	1.28

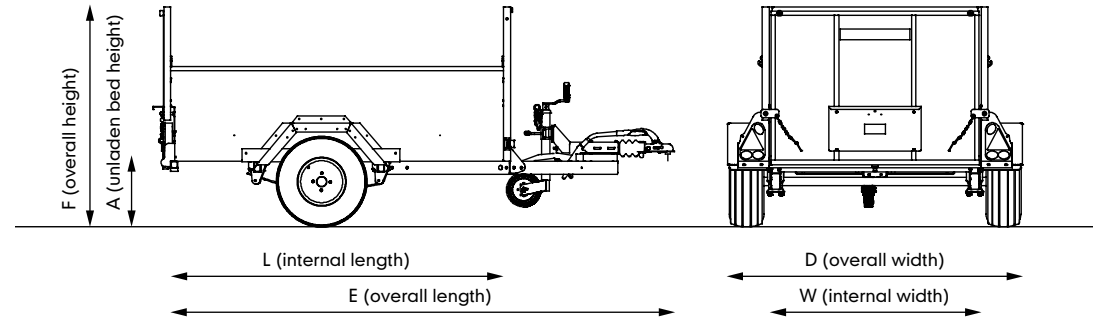

Optional lightguards



Leaf spring suspension is standard



Q5e off-road knobby tyres (22 x 11-8)



Q5/6/7e off-road flotation tyres (20.5 x 8-10)



Optional ramp gates available on Q6, 7 and 8



Swivel Hitch option available for off road use only (Not type approved for road use*)

Options

	Chassis	Unladen Weight	Maximum Gross Weight	Tyres	Spare Wheel and carrier	Lights	Mudguards	Stock Ramp	Hinged Mesh Sides	Hinged Solid Sides	Internal Partition**	Rear Prop Stands (Pair)	Jockey Wheel	Roof and Rack	Ramp Gates**	Light Guards	Swivel Hitch
Q5e Off-Road	Unbraked	185kg	350 kg @ 40kph	22 x 11-8*	-	No	No	Option	Option	Option	Option	Option	Option	Option	-	-	Option
Q5e Off-Road	Unbraked	185kg	750 kg	20.5 x 8-10	Option	No	No	Option	Option	Option	Option	Option	Option	Option	-	-	Option
Q6e Off-Road	Unbraked	235kg	750 kg	20.5 x 8-10	Option	No	No	Option	Option	Option	Option	Option	Option	Option	Option	-	Option
Q7e Off-Road	Unbraked	250kg	750 kg	20.5 x 8-10	Option	No	No	Option	Option	Option	Option	Option	Option	Option	Option	-	Option
Q5e Road	Unbraked	200kg	750 kg	20.5 x 8-10	Option	Yes	Yes	Option	Option	Option	Option	Option	Option	Option	-	Option	-
Q6e Road	Unbraked	250kg	750 kg	20.5 x 8-10	Option	Yes	Yes	Option	Option	Option	Option	Option	Option	Option	Option	Option	-
Q7e Road	Unbraked	265kg	750 kg	20.5 x 8-10	Option	Yes	Yes	Option	Option	Option	Option	Option	Option	Option	Option	Option	-
Q6b Road	Braked	300kg	1000 kg	195/55R10	Option	Yes	Yes	Option	Option	Option	Option	Option	Std	Option	Option	Option	-
Q7b Road	Braked	315kg	1000 kg	195/55R10	Option	Yes	Yes	Option	Option	Option	Option	Option	Std	Option	Option	Option	-
Q8b Road	Braked	390kg	1000 kg	195/55R10	Option	Yes	Yes	-	Option	Option	Option	Option	Std	Option	Option	Option	-

N.B SPARE WHEEL DOES NOT COME AS STANDARD

*All off-road trailers are not road legal. **For moving livestock commercially e.g. on the open road or to livestock markets, then you will need a roof and ramp side gates when loading/unloading (NB there may be derogations when transporting animals within 50km (30m) of your base).



Q5e off-road with hinged mesh sides, internal partition and stock ramp door



Q5e road with hinged mesh sides and propstands